

CAM570

— User Manual —

Warning

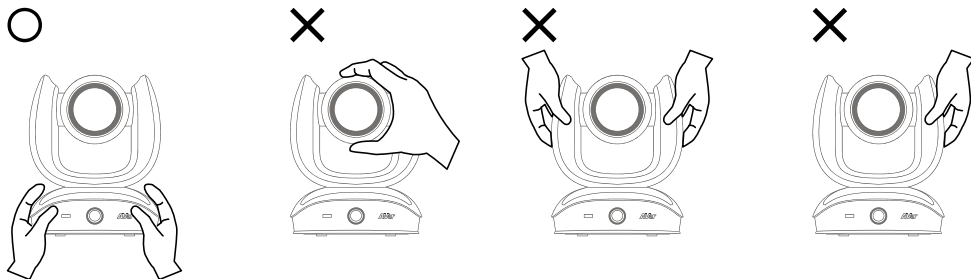

- Hold the bottom of the camera with both hands to carry the camera. Whether the camera is connected to power or not, do not grab any part of the lens or the lens holder to carry the camera or adjust pan and tilt.
- Do not drop the camera or subject it to physical shock.
- Ensure the power supply voltage is correct before using the camera.
- Do not place the camera where the cord can be stepped on as this may result in fraying or damage to the lead or the plug.
- To reduce the risk of fire or electric shock, do not expose the camera to rain or moisture. Warranty will be voided if any unauthorized modifications are done to the camera.

Federal Communications Commission Statement

NOTE: This equipment has been tested and found to comply with the limits for a Class A digital device, pursuant to part 15 of the FCC Rules. These limits are designed to provide reasonable protection against harmful interference when the equipment is operated in a commercial environment. This equipment generates, uses, and can radiate radiofrequency energy and, if not installed and used in accordance with the instruction manual, may cause harmful interference to radio communications. Operation of this equipment in a residential area is likely to cause harmful interference in which case the user will be required to correct the interference at his own expense.

FCC Caution: Any changes or modifications not expressly approved by the party responsible for compliance could void the user's authority to operate this equipment.

This device complies with part 15 of the FCC Rules.

Operation is subject to the following two conditions:

- (1) This device may not cause harmful interference, and
- (2) this device must accept any interference received, including interference that may cause undesired operation.

This Class A digital apparatus complies with Canadian ICES-003. Cet appareil numérique de la classe A est conforme à la norme NMB-003 du Canada.

Warning

This is a class A product. In a domestic environment this product may cause radio interference in which case the user may be required to take adequate measures.

Caution

Risk of explosion if battery is replaced by an incorrect type. Dispose of used batteries according to the instructions.

VCCI-A

この装置は、クラス A 機器です。この装置を住宅環境で使用すると電波妨害を引き起こすことがあります。この場合には使用者が適切な対策を講ずるよう要求されることがあります。

(注)本製品同梱の電源ケーブルは、本製品同梱の電源アダプタでのみ使用してください。
本製品同梱の電源ケーブルは、他の電気機器では使用できません。

사용자 안내문
이 기기는 업무용 환경에서 사용할 목적으로 적합성평가를 받은 기기로서 가정용 환경에서 사용하는 경우 전자파간섭의 우려가 있습니다.
※ 사용자 안내문은 "업무용 방송통신기자재"에만 적용됩니다.

기종별	사용자안내문
A 급 기기 (업무용 방송통신기자재)	이 기기는 업무용(A 급) 전자파적합기기로서 판매자 또는 사용자는 이 점을 주의하시기 바라며, 가정외의 지역에서 사용하는 것을 목적으로 합니다.

Remote Control Battery Safety Information

- Store batteries in a cool and dry place.
- Do not throw away used batteries in the trash. Properly dispose of used batteries through specially approved disposal methods.
- Remove the batteries if they are not in use for long periods of time. Battery leakage and corrosion can damage the remote control. Dispose of batteries safely and through approved disposal methods.
- Do not use old batteries with new batteries.
- Do not mix and use different types of batteries: alkaline, standard (carbon-zinc) or rechargeable (nickel-cadmium).
- Do not dispose of batteries in a fire.
- Do not attempt to short-circuit the battery terminals.

遥控器電池安全信息

- 请将電池存放在涼爽與乾燥的位置。
- 不要將電量用盡的電池棄置在家庭廢棄物中。請將電池棄置在特定回收處，或送回原購買的商店。
- 如果長時間不使用電池，請將其取出。電池漏液與腐蝕可能會損壞遙控器，請以安全方式棄置電池。
- 不可混用新舊電池。
- 不可混用不同類型的電池：鹼性、標準（碳鋅）或可充電（鎳鎘）電池。
- 不可將電池棄置于火源中。
- 請勿嘗試讓電池端子短路。

DISCLAIMER

No warranty or representation, either expressed or implied, is made with respect to the contents of this documentation, its quality, performance, merchantability, or fitness for a particular purpose.

Information presented in this documentation has been carefully checked for reliability; however, no responsibility is assumed for inaccuracies. The information contained in this documentation is subject to change without notice.

In no event will AVer Information Inc. be liable for direct, indirect, special, incidental, or consequential damages arising out of the use or inability to use this product or documentation, even if advised of the possibility of such damages.

TRADEMARKS

“AVer” is a trademark owned by AVer Information Inc. Other trademarks used herein for description purpose only belong to each of their companies.

COPYRIGHT

©2023 AVer Information Inc. All rights reserved. | November 9, 2023

All rights of this object belong to AVer Information Inc. Reproduced or transmitted in any form or by any means without the prior written permission of AVer Information Inc. is prohibited. All information or specifications are subject to change without prior notice.

More Help

For FAQs, technical support, software and user manual download, please visit:

Headquarters

Download Center: <https://www.aver.com/download-center>

Technical Support: <https://www.aver.com/technical-support>

USA Branch Office

Download Center: <https://www.averusa.com/business/support>

Technical Support: <https://averusa.force.com/support/s/contactsupport>

Europe Branch Office

Download Center: <https://www.avereurope.com/download-center>

Technical Support: <https://www.avereurope.com/technical-support>

Contact Information

Headquarters

AVer Information Inc.

<https://www.aver.com>

8F, No.157, Da-An Rd., Tucheng Dist., New Taipei City 23673, Taiwan

Tel: +886 (2) 2269 8535

USA Branch Office

AVer Information Inc., Americas

<https://www.averusa.com>

668 Mission Ct., Fremont, CA 94539, USA

Tel: +1 (408) 263 3828

Toll-free: +1 (877) 528 7824

Technical support: support.usa@aver.com

Europe Branch Office

AVer Information Europe B.V.

<https://www.avereurope.com>

Westblaak 134, 3012 KM, Rotterdam, The Netherlands

Tel: +31 (0) 10 7600 550

Technical support: eu.rma@aver.com

Japan Branch Office

アバー・インフォメーション株式会社

<https://jp.aver.com>

〒160-0023 日本東京都新宿区西新宿 3-2-26 立花新宿ビル 7 階

Tel: +81 (0) 3 5989 0290

テクニカル・サポート: <https://jp.aver.com/technical-support>

Vietnam Branch Office

Công ty TNHH AVer Information (Việt Nam)

Tầng 5, 596 Nguyễn Đình Chiểu, P.3, Quận 3,

Thành phố Hồ Chí Minh 700000, Việt Nam

TEL: +84 (0)28 22 539 21

Contents

Warning	2
Overview	1
Package Contents	1
Optional Accessories*	1
Pan and Tilt Angle.....	2
Parts Info	3
LED Indicator	3
Remote Control.....	4
Shortcuts.....	5
Connection	6
Device Connection.....	6
Power Connection	7
HDMI Connection	8
RS-232 Connection	10
RS-232 Port Pin Definition	10
Computer/Keyboard Controller and Camera Connection.....	11
Camera Cascade Connection	14
Installation	16
Wall Mount Installation.....	16
Ceiling Mount Installation (Optional)	19
Secure the Cables	22
Get Started	23
Make a Video Call.....	23
Web Interface	24
Access the Web Interface	24
AVer IP Finder	24
PTZApp 2.....	25
PTZ Control	26

Overview of PTZ Control.....	26
Save, Load and Clear a Preset.....	27
Add and Delete Available Presets (Presets 10-127).....	27
Setting	28
Overview of the Floating Live View.....	32
Tracking Mode	33
Gesture Control.....	35
Video Format	36
Network	37
System.....	38
PTZApp 2.....	40
Install PTZApp 2	40
Open and Quit PTZApp 2	40
Use PTZApp 2 with USB Devices.....	41
Virtual Stream.....	48
Smart Gallery.....	49
Audio Setting	50
EZLive.....	55
Use AVer EZLive.....	55

Overview

Package Contents

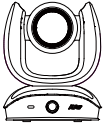

CAM570

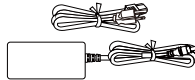

**Power Adapter &
Power Cord***



Remote Control



**AAA Battery (x2)
(US only)**

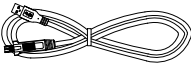

**USB 3.1 Type-B to
Type-A Cable (3m)**

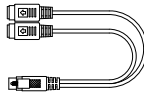

**Mini Din 9 to Mini Din 8
RS-232 Adapter Cable**

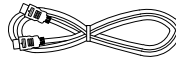

HDMI Cable (3m)

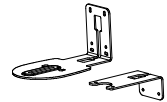

**Wall Mount
Bracket (x2)**



**M4 x 8mm
Wall Mount Screw (x2)**



**1/4"-20 L=7.5mm
Tripod Screw (x2)**

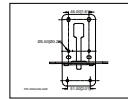

Drill Template



QR Code Card

*The power cord may vary based on the country or region where sold.

Optional Accessories*

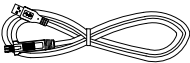

**USB 2.0 Type-B to
Type-A Cable (5m)**



**Mini Din 8 to D-Sub 9
Cable**

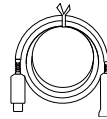

**USB 3.1 Extender
10m/20m/30m**

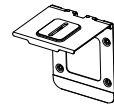

Foldable TV Mount



Ceiling Mount

*Optional Accessories may vary based on the country or region where sold.

Pan and Tilt Angle

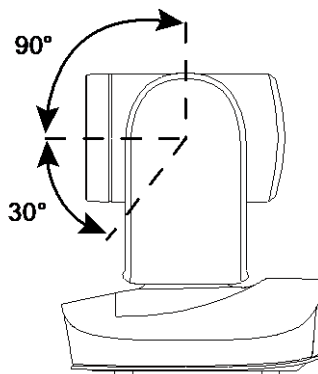
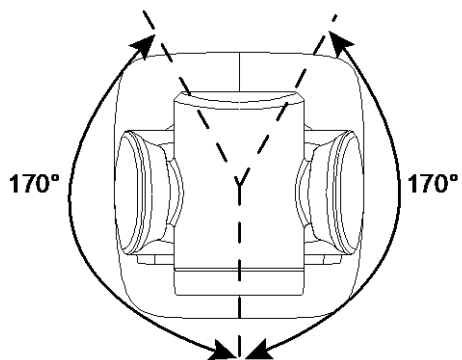

Parts Info

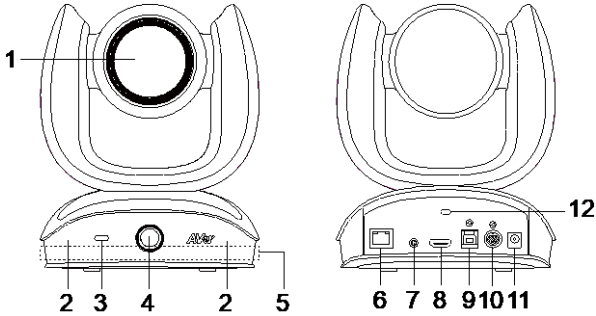





- 1. Optical Zoom Main Lens
- 2. IR Sensor
- 3. Status LED
- 4. AI Lens*
- 5. Built-in Microphone Array
(audio tracking only, cannot be used as a video conference audio source)
- 6. PoE Port
(compatible with IEEE 802.3at)
- 7. Audio Input Port
- 8. HDMI Port
- 9. USB 3.1 Type-B Port
- 10. RS-232 In/Out Port
- 11. DC Power Jack
- 12. Kensington Lock

LED Indicator

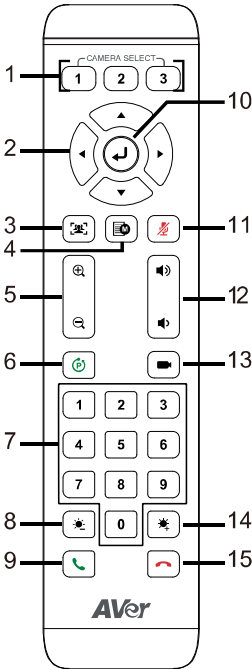











Color	Status
Solid red	Start-up
Solid orange	Standby
Solid blue	Video on
Flashing blue for 2 seconds	Gesture control is turned on
Flashing blue for 4 seconds	Performing a gesture command

Remote Control



Name	Function
1. Camera Select	<p>No selection is required by default to operate the camera.</p> <ul style="list-style-type: none"> ● Camera Binding is turned off by default and all three selections can operate the camera. ● To specify a number, go to Setting > Camera Binding on the web interface or in PTZ App2.
2. Directional Pad	Press once for incremental movement or press and hold for continuous pan or tilt.
3. SmartFrame	<p>Short press to frame entire group on screen and remove excess space. Long press to switch between tracking modes.</p> <p>Note:</p> <ul style="list-style-type: none"> ● The SmartFrame icon  appears on video when turned on. To hide the icon, go to the Setting tab > On-Screen Menu > Off on the web interface or in PTZ App2. ● The effective distance is up to 7-10 meters. ● All functions will be turned off if pan, tilt and zoom controls are used.
4. OSD Menu	Short press to open the OSD menu during HDMI output. Press and hold for 1 second to select a screen layout or picture-in-picutre (PiP).
5. Zoom In/Out	Zoom in or out.
6. Preset	<ul style="list-style-type: none"> ● To save a preset: Press and hold the Preset button  until the save message appears on screen and release, then short press the Number Pad (0-9). ● To load a preset: Press and hold the Preset button  and release, then short press the Number Pad (0-9).
7. Number Pad	
8. Brightness -	Decrease image brightness.
9. Call/Answer	N/A
10. Enter	Display current AI function during HDMI output.
11. Mute	N/A
12. Volume	N/A
13. Load Preset	With each press, cycle through defined presets.
14. Brightness +	Increase image brightness.
15. Hang Up	N/A

Shortcuts

Press and Hold	To
 for 2 sec	Turn wide dynamic range (WDR) on or off.
 for 2 sec	Enable Audio Tracking .
 for 2 sec	Enable Presentation Mode .
 for 2 sec	Turn SmartFrame on or off.
 for 2 sec	Change the picture-in-picutre (PiP) position when streaming over USB or IP.
 for 2 sec	Turn RTMP streaming on or off when RTSP and RTMP are turned on.
 for 2 sec	Enter sleep mode.
 for 6 sec	Reboot.
 for 2 sec and release, then press 	Turn Preset Link Set 1 on or off.
 for 2 sec and release, then press 	Turn Preset Link Set 2 on or off.

Connection

Device Connection

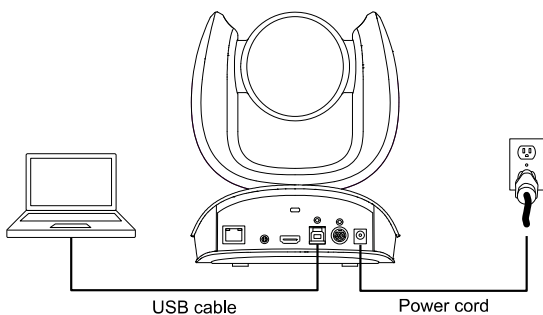

- Use the included USB cable.
- The USB 3.1 port is compatible with USB 2.0.

Maximum resolution/fps for USB 2.0 and USB 3.1 ports:

USB 2.0		USB 3.1		HDMI
YUV	M-JPEG	YUV	M-JPEG	
- 640x480 or less, up to 30fps - 720p, up to 10fps	- 1080p/60fps	- Up to 1080p/30fps - 720p/60fps	- Up to 4k/30fps - 1080p/60fps	- 1080p/60fps - 1080p/30fps

Power Connection

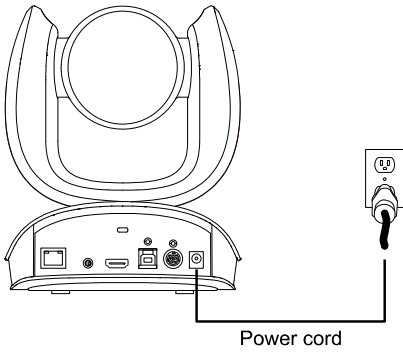

Connect the included power adapter and power cord to a wall outlet.

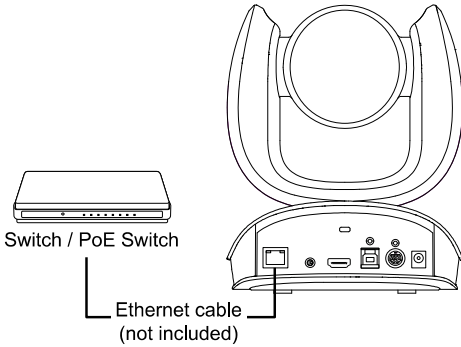

Or connect a CAT 5e FTP cable (not included) to the PoE Switch or Ethernet.

- PoE port is compatible with IEEE 802.3at.
- When streaming over IP, use a CAT 5e FTP cable (not included) for a smooth video.

HDMI Connection

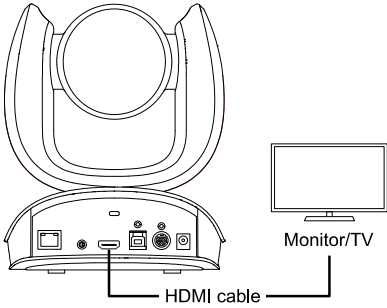

Connect with TV or monitor through the HDMI port to display camera video on the screen. Hold  button for 1 second on the Remote Control to call out the screen layout option. Select the camera image layout firstly. The default is PIP1, showing optical zoom lens image as main screen and AI lens image as small view. Under this layout, you can switch two cameras by pressing Up/Down on remote control.

[Note]

The HDMI out function will be automatically disabled when 4K resolution is selected for USB or RTSP streaming. Under this circumstance, please change RTSP and USB streaming from 4K to lower resolution if you want to enable HDMI out.

If your camera is under RTSP 4K resolution, you can press and hold the OSD Menu button on the Remote Control for 1~2 sec. to quickly change the resolution to 1080p and then you can start using the HDMI function.

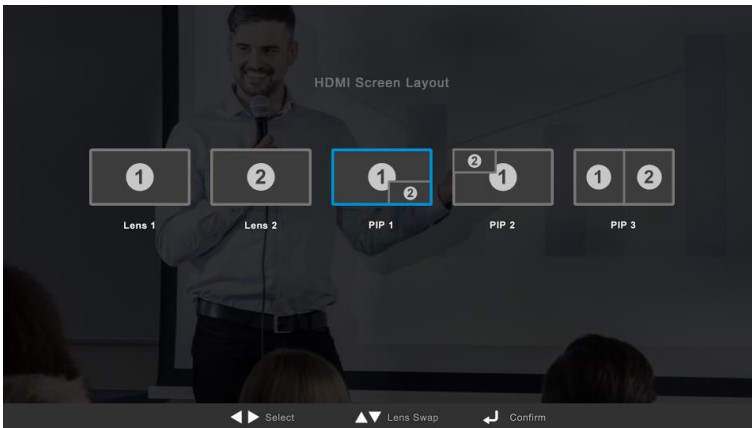

PIP View

Lens 1 The PTZ camera focuses on speaker

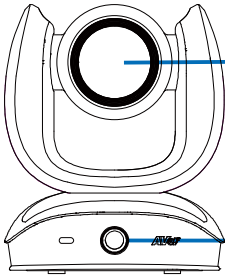

Lens 2 Shows all participants

After choosing the image layout, short press the OSD Menu button on the Remote Control and then the setting page will show up. Press right direction button to enter and configure the parameters of the camera. Short press the OSD button twice or hold it for 1 sec. to leave. The HDMI OSD setting function is the same as Web configuration interface. Please refer to [Web Settings](#) for more details.

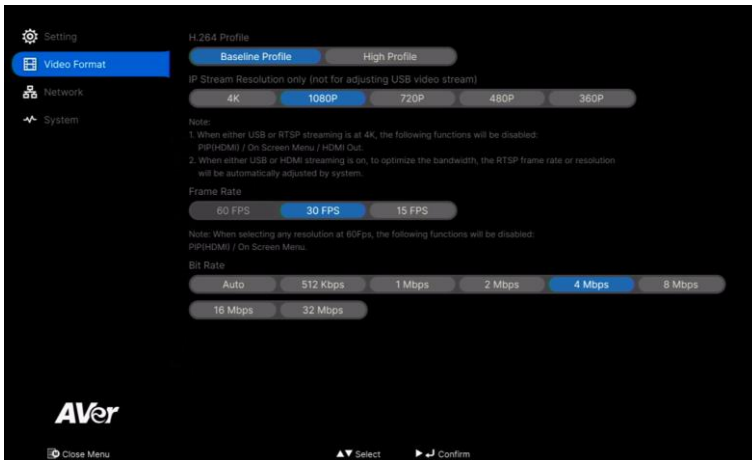

RS-232 Connection

RS-232 Port Pin Definition

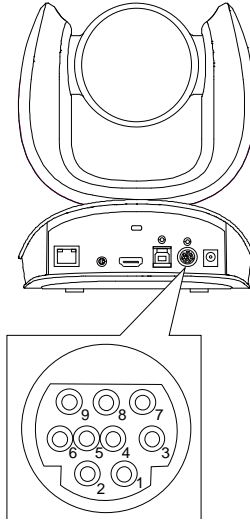

Function	Mini DIN9 PIN #	I/O Type	Signal	Description
VISCA IN	1	Output	DTR	Data Terminal Ready
	2	Input	DSR	Data Set Ready
	3	Output	TXD	Transmit Data
	6	Input	RXD	Receiver Data
VISCA OUT	7	Output	DTR	Data Terminal Ready
	4	Input	DSR	Data Set Ready
	8	Output	TXD	Transmit Data
	9	Input	RXD	Receiver Data
	5	---	---	---

Computer/Keyboard Controller and Camera Connection

Direct Connection

If users do not use AVer RS-232 adapter cable, please refer to the pin connection shown below.

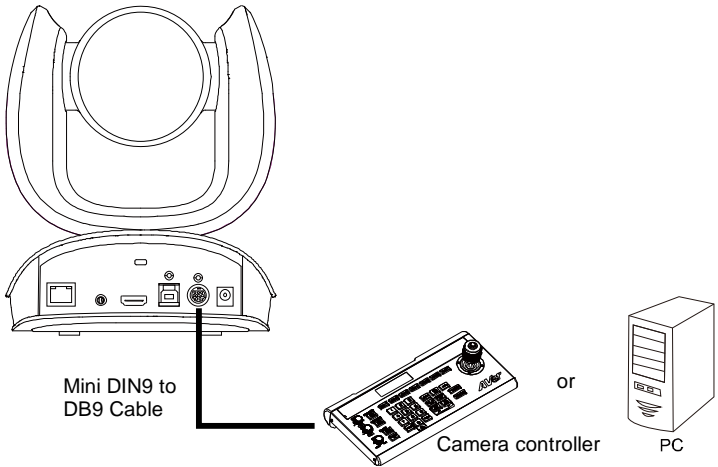

Mini DIN9

Camera

- 1. DTR (IN)
- 2. DSR (IN)
- 3. TXD (IN)
- 6. RXD (IN)
- 7. DTR (OUT)
- 4. DSR (OUT)
- 8. TXD (OUT)
- 9. RXD (OUT)

DB9

Camera controller, PC

- 6. DSR
- 4. DTR
- 2. RXD
- 3. TXD
- 1. DCD
- 5. GND
- 7. RTS
- 8. CTX
- 9. RI

Use the supplied RS-232 mini DIN9 to mini DIN8 cable

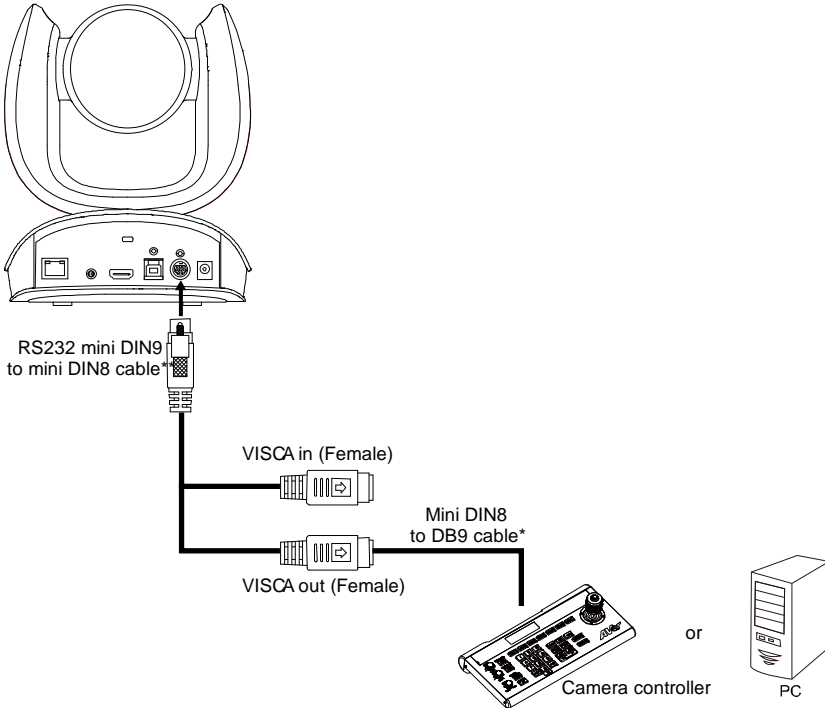

DB9

Camera controller, PC

- 1. DCD
- 2. RXD →
- 3. TXD →
- 4. DTR →
- 5. GND →
- 6. DSR →
- 7. RTS
- 8. CTX
- 9. RI

Mini DIN8

Camera

- 6. GND (IN)
- 3. TXD (IN)
- 5. RXD (IN)
- 2. DSR (IN)
- 4. GND (IN)
- 1. DTR (IN)
- 1. DTR (OUT)
- 2. DSR (OUT)
- 3. TXD (OUT)
- 4. GND (OUT)
- 5. RXD (OUT)
- 6. GND (OUT)

* Mini DIN8 to D-Sub9 (DB9) cable 064AOTHERBPK is an optional item.

** RS-232 mini DIN9 to mini DIN8 Cable Pin Definition

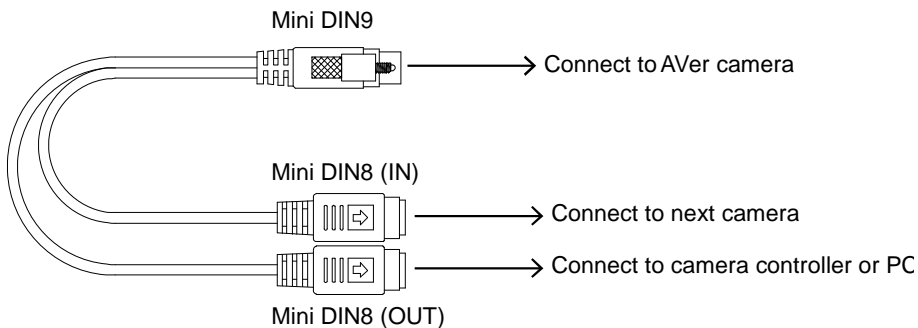

Mini DIN8 Pin Definition

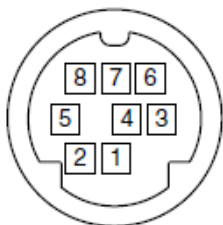

No.	Pin
1	DTR
2	DSR
3	TXD
4	GND
5	RXD
6	GND
7	NC
8	NC

Camera Cascade Connection

Direct Connection

If users do not use AVer RS-232 adapter cable, please refer to the pin connection shown below for cascading cameras.

Total can connect up to 7 cameras.

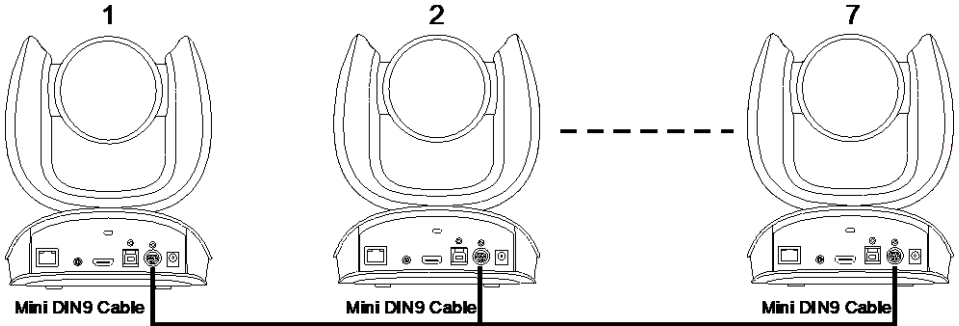

Mini DIN9

Camera 1

1. DTR (IN)

2. DSR (IN)

3. TXD (IN)

6. RXD (IN)

7. DTR (OUT)

4. DSR (OUT)

8. TXD (OUT)

9. RXD (OUT)

SHIELD

Mini DIN9

Camera 2

7. DTR (OUT)

4. DSR (OUT)

8. TXD (OUT)

9. RXD (OUT)

2. DSR (IN)

1. DTR (IN)

6. RXD (IN)

3. TXD (IN)

SHIELD

→

→

→

→

→

Use the RS-232 mini DIN9 to mini DIN8 cable

Total can connect up to 7 cameras.

To facilitate the camera cascade, users can use AVer RS-232 adapter cable.

Connect camera with AVer mini DIN9 to mini DIN8 adapter cable. Connect the mini DIN8 female side to male mini DIN8 Visca cable (Users have to buy it in the market) and then connect AVer mini DIN9 to mini DIN8 adapter cable again to connect to next camera.

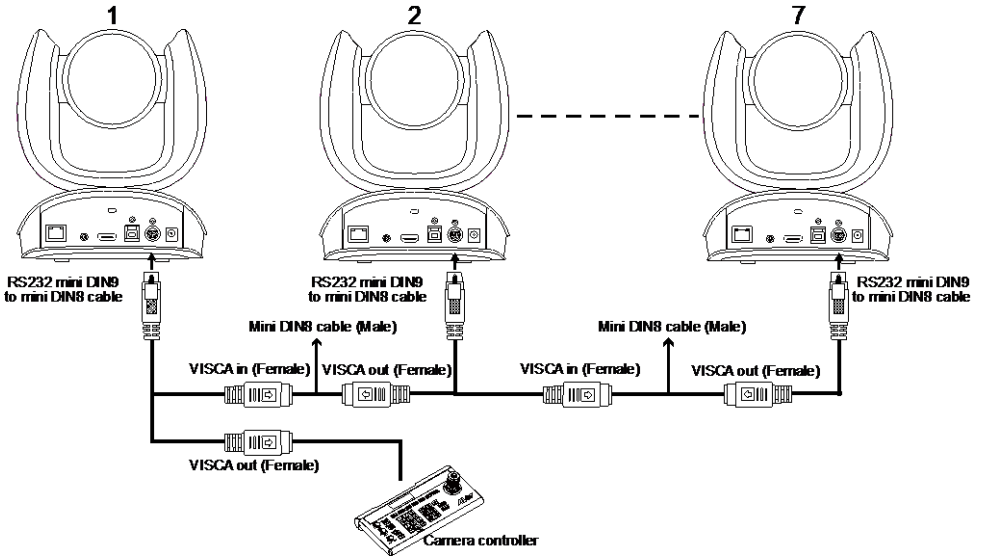

Mini DIN8

Camera 1

1. DTR (IN)
2. DSR (IN)
3. TXD (IN)
4. GND (IN)
5. RXD (IN)
6. GND (IN)

Mini DIN8

Camera 2

1. DTR (OUT)
2. DSR (OUT)
3. TXD (OUT)
4. GND (OUT)
5. RXD (OUT)
6. GND (OUT)

- | | | |
|--------------|---|-------------|
| 1. DTR (OUT) | → | 2. DSR (IN) |
| 2. DSR (OUT) | → | 1. DTR (IN) |
| 3. TXD (OUT) | → | 5. RXD (IN) |
| 4. GND (OUT) | → | 4. GND (IN) |
| 5. RXD (OUT) | → | 3. TXD (IN) |
| 6. GND (OUT) | | 6. GND (IN) |

Installation

- The AI lens has a 95-degree field of view but lacks ePTZ functionality.
- Install the camera at a minimum height of 1.5 meters and avoid placing the camera on a table as it may obstruct the AI lens view.
- Keep the camera at least 1.5 meters away from your participants for accurate framing.

Wall Mount Installation

1. Use the drilling paper included in the package to drill the holes in the wall where the user wants to mount the camera.

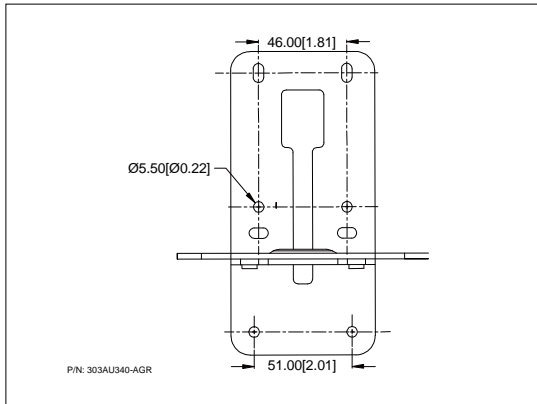

2. Use the screws (not included) to secure the L-mount bracket **A** on the wall.

Screw

For Cement wall: M4 x20mm self-tapping screws (x4) + Plastic conical anchor

For Wooden wall: M4 x20mm self-tapping screws (x4)

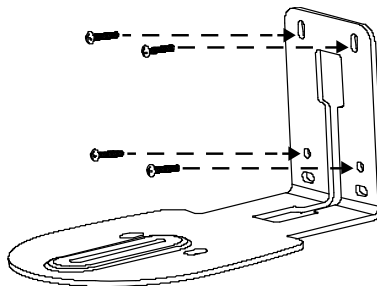

3. Then, assemble the L-mount brackets **A** + **B** with screws (included in package).

Screw size:  M4 x8mm (x2)

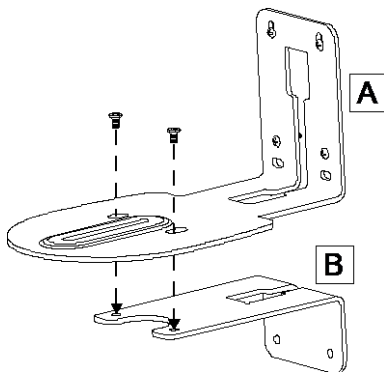

4. After assembling the L-mount brackets, use the screws (not included) to secure the lower part of L-mount brackets on the wall.

Screw

For Cement wall: M4 x20mm self-tapping screws (x2) + Plastic conical anchor

For Wooden wall: M4 x20mm self-tapping screws (x2)

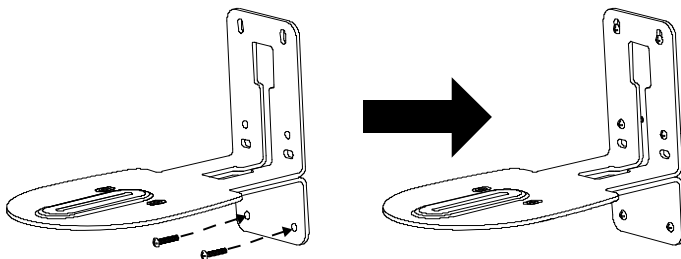

5. Pass the cables through the hole on the L-mount bracket and connect the cables to corresponding connection ports.

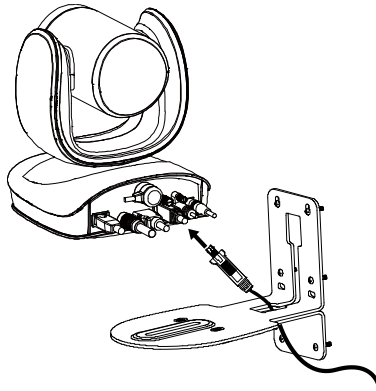

6. Use the remaining screws (included in package) to secure the camera on the L-mount bracket.

Screw:  1/4"-20 L=7.5mm (x2)

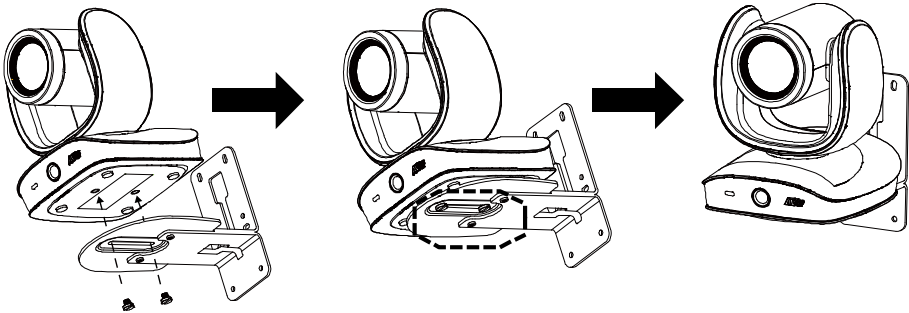

Ceiling Mount Installation (Optional)

Use the ceiling mount bracket to install the camera to the ceiling.

Package Content

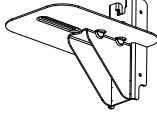
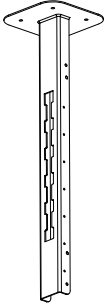

Mount bracket x 1

Camera bracket x 1

Back cover x 1

Screw (M4*8) x 8

Washer x 8

Dimension

Unit=mm

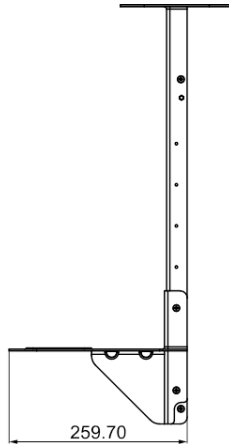
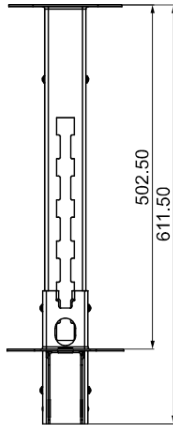
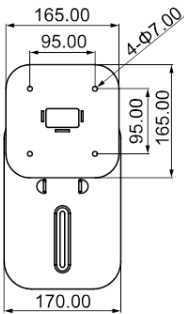

To mount the camera to the ceiling:

1. Drill the hole on the ceiling. Use screw to secure the mount bracket on the ceiling.

Screw: 4 M6 x 50mm (Not included in package)

2. Use the supplied screws with washers to secure the camera bracket to the mount bracket.

Screw: 4 M8 x 4 + 4 Washer

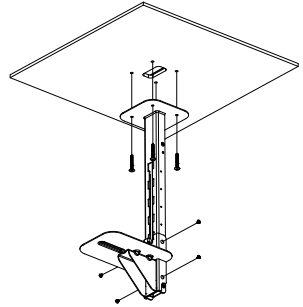

3. Connect all cables on the camera and pass all cables out through the hole on the mount bracket. Then, secure the camera on the camera bracket.

Screw: 2 UNC-1/4"-20 (Not included in package)

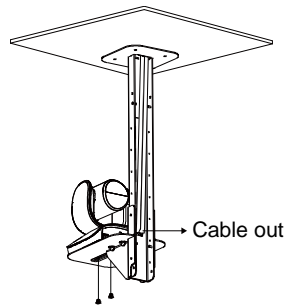

4. Organize all cables to go out from top or bottom of mount bracket.
5. Then, secure the back cover with screws and washer.

Screw: 4 M8 x 4 + 4 Washer

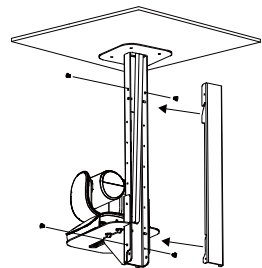

6. Completed.

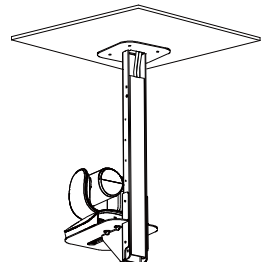

To mount the camera to the calcium silicate ceiling:

1. Please purchase support bracket for supporting camera mount bracket on calcium silicate ceiling. Then, secure the support bracket on the light steel frame structure.
2. Drill the hole on the calcium silicate ceiling. Open a hole on the calcium silicate ceiling to allow camera cables to pass through.
3. Then, secure the mount bracket, calcium silicate ceiling and support bracket together.

Screw: 4 Wingnut + 4 M6x50mm (Not included in package)

4. Use the supplied screws with washers to secure the camera bracket to the mount bracket.

Screw: 4 M8 x 4 + 4 Washer

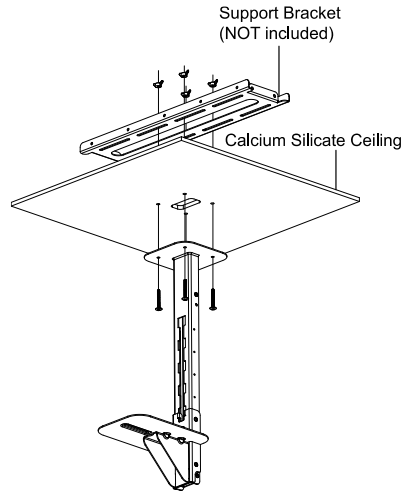

5. Connects all cables on the camera and pass all cables through the hole on the mount bracket. Organize all cables to pass through the hole on the ceiling. Also, the cable can go out from top or bottom of mount bracket.

6. Then, secure the camera on the camera bracket.

Screw: 2 UNC-1/4"-20 (Not included in package)

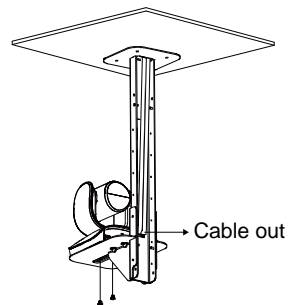

7. Next, secure the back cover with screws and washer.

Screw: 4 M8 x 4 + 4 Washer

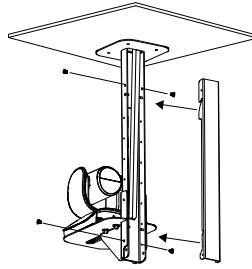

8. Completed.

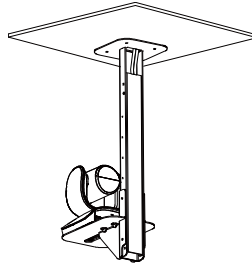

Secure the Cables

Plug in your USB cable or RS-232 cable and tighten the cable screw to secure.

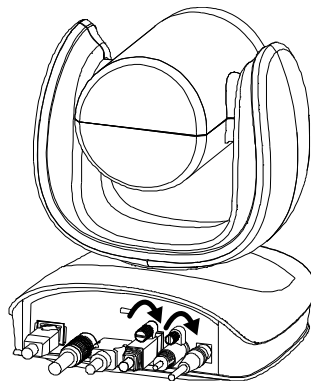

Get Started

Make a Video Call

The CAM570 is a plug-n-play camera.

1. Connect your CAM550 to a computer using the included USB cable.
2. Open your video conferencing software such as Microsoft® Teams, Skype and Zoom.
3. Set the CAM570 as your primary camera on your video conferencing software.

Web Interface

Access the Web Interface

You can access your camera's web interface and change the default static IP to DHCP using the following software:

- AVer IP Finder
- PTZApp 2

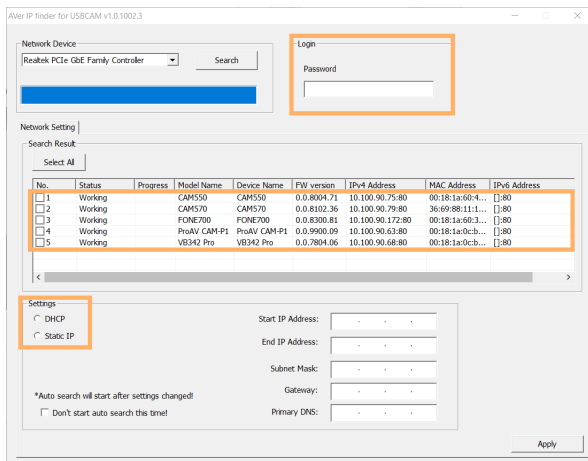

AVer IP Finder

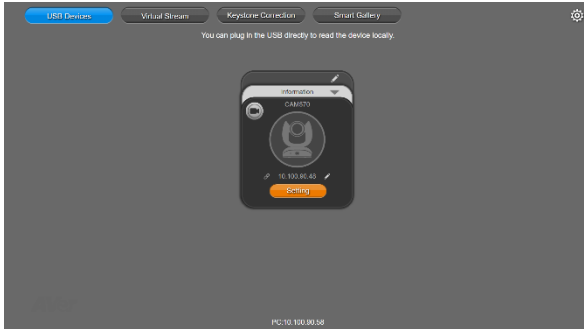

1. Download and install AVer IP Finder to your computer from AVer Download Center. (<https://www.aver.com/download-center>).
2. Make sure your camera and computer are connected to the same network.
3. Open AVer IP Finder. Click **Search**.
4. To change the default static IP **192.168.1.168** to DHCP, select your camera's checkbox from the list of devices.
5. Enter the default password **aver4321**.
6. Select **DHCP**.
7. Click **Apply**. AVer IP Finder will search for devices again and your camera's IP address will change.
8. Double-click on your device row to access the web interface.
9. For first-time login, enter the default password **aver4321**. You'll be prompted to set up a new account and password.
 - Use 6-10 characters, upper and lowercase letters, numbers and special characters (* ! % + = , - _ ^ / @ . -).
 - If you forgot your password, use PTZApp 2 to reset the password to the default password **aver4321**.

PTZApp 2



1. Download and install PTZApp 2 to your computer from AVer Download Center. (<https://www.aver.com/download-center>).
2. Make sure your camera and computer are connected to the same network.
3. Double-click the PTZApp 2 icon  to open PTZApp 2 in your browser.
 - Recommended browser: Chrome 76 and above, Firefox 69 and above.
4. Connect your camera to your computer using the included USB cable. When PTZApp 2 detects a USB-connected camera, a camera card will appear under the **USB Devices** page.
5. Click the pencil icon  on the camera card to change the default static IP **192.168.1. 168** to DHCP.
6. Select **DHCP** and click **Confirm**.



7. Click the link icon  on the camera card to access the web interface.
8. For first-time login, enter the default password **aver4321**. You'll be prompted to set up a new account and password.
 - Use 6-10 characters, upper and lowercase letters, numbers and special characters (* ! % + = , - _ ^ / @ . ~).
 - If you forgot your password, use PTZApp 2 to reset the password to the default password **aver4321**.

PTZ Control

Overview of PTZ Control

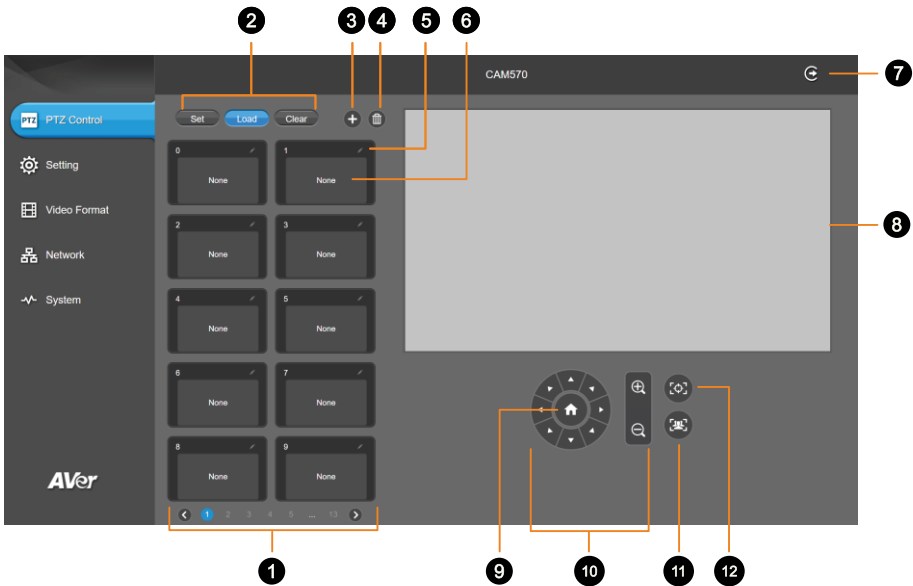

1. Presets 0-9

2. Preset Function Buttons

Save, load and clear a preset.

3. Add Available Presets

There are 10 available presets 0-9 by default. Click the plus icon to add up to 128 available presets.

4. Delete Available Presets

Click a trashcan icon to delete available presets.

5. Name

Click the pencil icon to name a preset.

6. Preset Thumbnail

7. Log Out

Log out of your account and close the web interface.

8. Live View

9. Pan-Tilt Reset

Reset the pan-tilt position to the center.

10. Directional Pad and Zoom

11. SmartFrame

Click the SmartFrame icon  to frame entire group on screen and remove excess space.

Note: The SmartFrame icon  appears on video when turned on. To hide the icon, go to the **Setting** tab > **On-Screen Menu** > **Off** on the web interface.

12. One-Touch Focus

Click to autofocus once.

Save, Load and Clear a Preset



To save a preset:

1. Use the pan, tilt and zoom controls to position your camera.
2. Select **Set**, then a preset number to save that position.
3. Select **Yes** when prompted. A thumbnail of your preset will appear.

Add and Delete Available Presets (Presets 10-127)

There are 10 available presets 0-9 by default.

Click the plus icon to add up to 128 available presets, or click the trashcan icon to delete available presets.

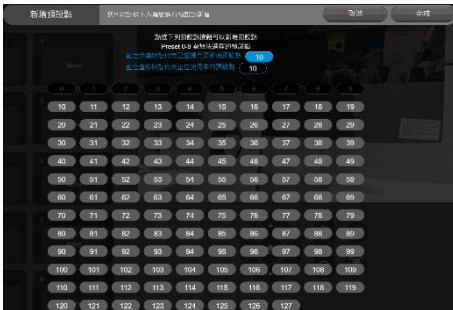

Add



Delete

To add an available presets:

1. Select the plus icon, then select the preset numbers you want to add.
2. Select **Done**.

To delete an available preset:

1. Select the trashcan icon, then select the preset numbers you want to delete.
2. Select **Done**.

Setting

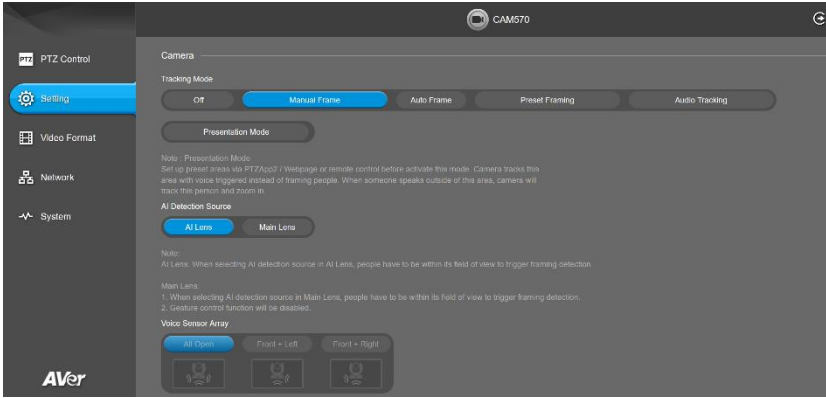

Camera

Item	Description
Tracking Mode	Select a tracking mode. Refer to < Tracking Mode > for details.
AI Detection Source	Select a lens to perform for AI detection. Entire group must fit inside the selected lens's field of view.
Voice Sensor Array	Turn Voice Sensor Array on or off. <ul style="list-style-type: none"> Main lens must be set as AI detection lens.
Camera Moving Speed	Select a camera moving speed.
Framing Speed	Select a duration before auto frame. <ul style="list-style-type: none"> Slow: 5 seconds before auto frame. Middle: 3 seconds before auto frame. High: 1 second before auto frame.
Framing Size	Select a framing size to include or remove excess space on either side of the subject.
Transition Effect	Select a transition effect for Audio Tracking . <ul style="list-style-type: none"> PTZ Movement: Use pan-tilt-zoom transition. Smart ViewShift: <ul style="list-style-type: none"> Use dissolve effect, pan-tilt-zoom transition or a mix of both based on the distance of camera travel, to minimize disorienting movements. Available under Audio Tracking and Presentation Mode. AI lens must be set as AI detection lens. Smart ViewShift uses only pan-tilt-zoom transition for output over 1080p.
Audio Tracking Response Speed	Select an audio tracking response speed. Slower response speeds can be useful for ignoring short utterances during audio tracking..

	<ul style="list-style-type: none"> ● Slow Speed: 4 second before audio tracking. ● Middle Speed: 2 seconds before audio tracking. ● High Speed: Fastest audio tracking response speed. 												
Audio Tracking Idle Interval	Select a duration for the camera to frame entire group after it detects no sound. If Off is selected, the camera will stay at the last position.												
Conversation Mode Trigger Sensitivity	<p>Drag the slider to select a sensitivity level with which your camera picks up on a conversation and frame entire group on screen.</p> <table border="1"> <tr> <td>Sensitivity</td> <td>Off</td> <td>1</td> <td>2</td> <td>3</td> <td>4</td> </tr> <tr> <td>Entry</td> <td>Never</td> <td>9th sound source change</td> <td>7th sound source change</td> <td>5th sound source change</td> <td>3rd sound source change</td> </tr> </table>	Sensitivity	Off	1	2	3	4	Entry	Never	9 th sound source change	7 th sound source change	5 th sound source change	3 rd sound source change
Sensitivity	Off	1	2	3	4								
Entry	Never	9 th sound source change	7 th sound source change	5 th sound source change	3 rd sound source change								
Gesture Control	<p>Turn Gesture Control on or off.</p> <ul style="list-style-type: none"> ● AI lens must be set as AI detection lens. ● The effective distance is up to 5 meters. ● Click the question mark icon to see a list of gesture commands or refer to <Gesture Control> for details. 												
Autofocus	Automatically focus after each pan, tilt and zoom, or automatically focus continually.												
Camera Focus	Adjust the focal length manually by dragging the slider or automatically.												
Home Position	Select a home position that your camera moves to when powered on.												
Sleep Position	Select a home position that your camera moves to when entering standby mode.												
Sleep Timer	<p>Set a duration before standby mode.</p> <ul style="list-style-type: none"> ● When transmitting video over USB, RTSP or RTMP, the camera won't enter standby mode. 												
On-Screen Menu	<p>Turn On-Screen Menu on or off.</p> <ul style="list-style-type: none"> ● Load Preset Off: Displays all statuses except load preset. 												
Camera Binding	<p>No setup is required to operate the camera.</p> <ul style="list-style-type: none"> ● When camera binding is turned off (default), all selections on the remote control can operate the camera. ● Or select Camera 1-Camera 3 to assign the camera to a camera select button 1-3 on the remote control. 												
Save Preset	<p>Turn Save Preset on or off.</p> <ul style="list-style-type: none"> ● When Save Preset is turned off, you won't be able to save presets using the remote control, web interface, hotkeys or VISCA commands. 												

PIP

Item	Description
PIP Layout	Turn picture-in-picture (PiP) on to see live view from both lenses.
HDMI Screen Layout	Select a layout for HDMI output. Click the arrows button to switch the position of the smaller video.
USB / IP Streaming Screen Layout	Select a layout for streaming over USB and IP. Click the arrows button to switch the position of the smaller video.

Image

Item	Description
Image Flip	<p>Flip the image vertically.</p> <ul style="list-style-type: none"> When Image Flip is turned on, AI Detection Source will default to the main lens, expecting an upside down installation.
Image Mirror	Flip the image horizontally.
WDR	Turn wide dynamic range (WDR) on or off.
Flicker Decrease on IFP / Monitor	<p>Turn Flicker Decrease on IFP / Monitor on or off.</p> 
Frequency	Select a frequency.
Main Lens 1 / AI Lens 2	Select a lens to set up White Balance , Noise Reduction , Brightness , Sharpness and Saturation . These settings will only apply to the selected lens.
White Balance	<p>Select a white balance setting:</p> <ul style="list-style-type: none"> Manual: Adjust the white balance manually by dragging the slider. Auto: Adjust the white balance automatically.
Noise Reduction	Adjust noise reduction level.
Brightness	Adjust brightness level.
Sharpness	Adjust sharpness level.
Saturation	Adjust saturation level.
Low Light Compensation	Turn Low Light Compensation on or off.
Low Resolution under 720p (except 848*480)	Enable to transmit video in 720p or lower.
Enlarge Total Zoom Up to 36x	Enable or disable Enlarge Total Zoom Up to 36x. The default is 24X.
Video Frame Rate	Select a video frame rate.

RS-232

Item	Description
ADDR	Select your settings to set up an RS-232 connection.
Baud Rate	
Protocol	
VISCA over IP	

Overview of the Floating Live View

- The floating live views opens automatically in the **Setting** tab.
- To open the floating live view again after closing, click on the camera icon on top of **Setting, Video Format, Network** and **System** tabs.

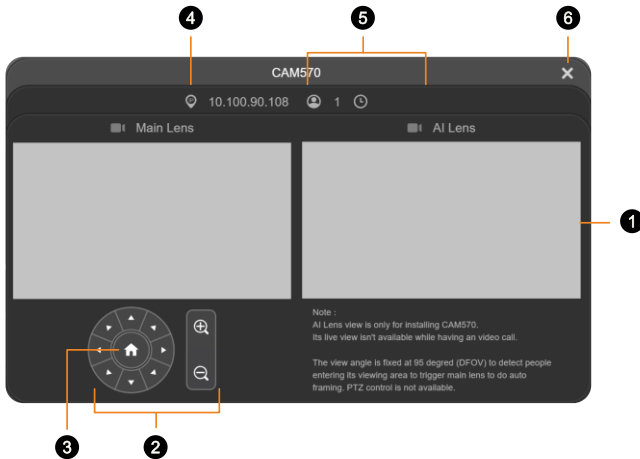

1. Live View

2. Directional Pad and Zoom

3. Pan-Tilt Reset

Reset the pan-tilt position to the center.

4. IP Address

5. Head Count and Video Transmission Duration

Click the head count icon to display head count and the duration of your video transmission. Click the icon again to hide the information.

6. Close

Click the X icon to close the floating live view and stop transmitting video.

Tracking Mode

Manual Frame

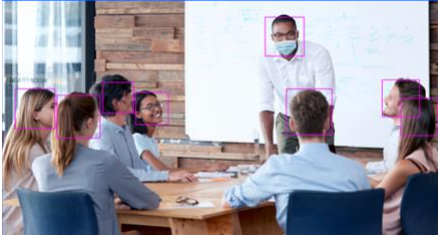

Frames manually using the SmartFrame button  to frame entire group on screen once.

Auto Frame

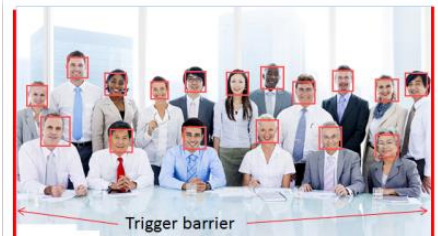

Frames entire group on screen automatically. If no one is in view, the camera will default to preset 0.

- The camera auto frames every time a subject enters or leaves the screen.
- If Auto Frame happens too frequently, set a duration before auto frame in the **Setting** tab > **Framing Speed**.
- You can set either AI lens or main lens as AI detection lens in the **Setting** tab > **AI Detection Lens**.

Preset Framing



Frames the presenter in real time as they move using presets. If no one is within the presets, the camera will default to group framing.

- Make sure you have defined presets. Presets 1-9 are available. Preset 0 defaults to the home position.
- Define overlapping presets for a smooth transition. When the presenter exits the previous preset, the camera will follow and move to the next preset.
- When multiple presenters are within presets, the preset with the smaller number takes priority.

Audio Tracking

Frames active speaker on screen.

If no one is speaking, the camera will stay at the last position or default to group framing after your selected **Audio Tracking Idle Interval**.

- You can set a duration before the camera default to group framing in the **Setting** tab > **Audio Tracking Idle Interval**.
- The built-in microphone array is for audio-tracking and cannot be used as an audio source during a video conference. To set up external microphones, download PTZApp 2 and go to the **Audio** tab.
- To reduce potential echoes, we recommend that you install the camera at least 1 meter away from the left and right walls or reflective surfaces.

Presentation Mode



A combination of presets (not Preset Framing) and Audio Tracking.

Uses presets when active speaker is speaking inside of presets; uses Audio Tracking and frames active speaker on screen when they are speaking outside of presets.





If no one is speaking, the camera will stay at the last position or default to group framing after your selected **Audio Tracking Idle Interval**.

- Make sure you have defined presets for audio tracking. Presets 1-9 are available. Preset 0 defaults to the home position.
- You can set a duration before the camera default to group framing in the **Setting** tab > **Audio Tracking Idle Interval**.

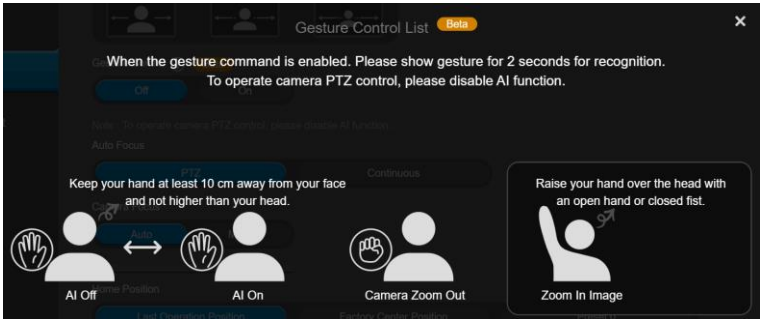
Gesture Control

- Turn on Gesture Control in the **Setting** tab > **Gesture Control**.
- AI lens must be set as AI detection lens. You must be inside the AI lens field of view.
- The effective distance is up to 5 meters.



Gesture	Description
	<p>Place your hand next to your face with your palm open and facing the camera for 2-3 seconds to turn Auto Frame on or off. Keep your hand 10cm away from your face.</p>
	<p>Raise your hand over your head for 2-3 second to zoom in.</p> <ul style="list-style-type: none"> ● Tracking Mode will be turned off when you zoom in or out with gestures. To turn on Tracking Mode again, do one of the following: <ol style="list-style-type: none"> 1. Use gesture to turn on Auto Frame. 2. Long press the SmartFrame button  on the remote control to switch between tracking modes. 3. Web interface: go to the Setting tab > Tracking Mode. 4. PTA App 2: go to the Setting tab > Tracking Mode.
	<p>Place your fist next to your face with your fist facing the camera for 2-3 seconds to zoom out. Keep your fist 10cm away from your face.</p> <ul style="list-style-type: none"> ● Tracking Mode will be turned off when you zoom in or out with gestures. To turn on Tracking Mode again, do one of the following: <ol style="list-style-type: none"> 1. Use gesture to turn on Auto Frame. 2. Long press the SmartFrame button  on the remote control to switch between tracking modes. 3. Web interface: go to the Setting tab > Tracking Mode. 4. PTA App 2: go to the Setting tab > Tracking Mode.

Video Format

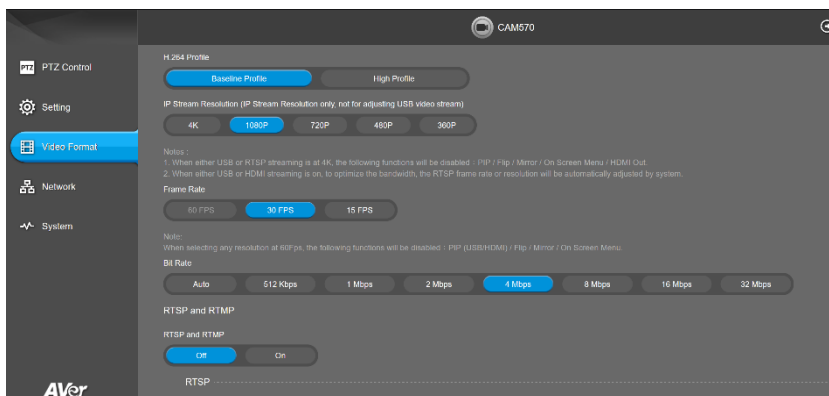

Item	Description
H.264 Profile	Select a profile for streaming live.
IP Stream Resolution	Select a resolution for streaming over IP.
Frame Rate	Select a frame rate.
Bit Rate	Select a bit rate. <ul style="list-style-type: none"> To live stream on Facebook, we recommend a bit rate under 4Mbps.

RTSP and RTMP

Item	Description	
RTSP and RTMP	Turn RTSP and RTMP on or off.	
RTSP	Require Password	Turn Require Password on or off.
	Set RTSP Access Password	Set or change an RTSP access password.
	RTSP URL Address	Displays RTSP URL address.
RTMP	Server URL	Copy and paste your video platform's server URL and stream key.
	Stream Key	
	Start Using RTMP	Click Start to start streaming, Stop to stop streaming.

Network

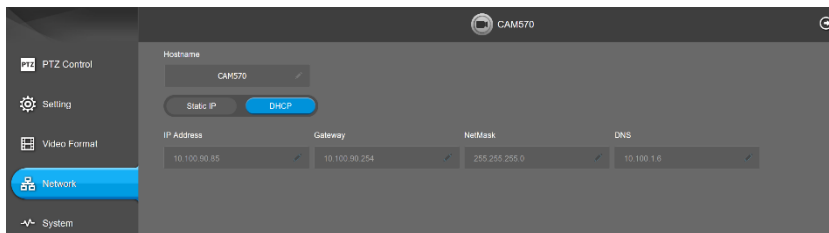

Item	Description
Hostname	Click the pencil icon to edit a hostname. Use upper and lowercase letters and numbers.
Static IP, DHCP	Set up static IP or DHCP. If Static IP is selected, enter your network settings to set up a static IP connection and click Confirm .

System

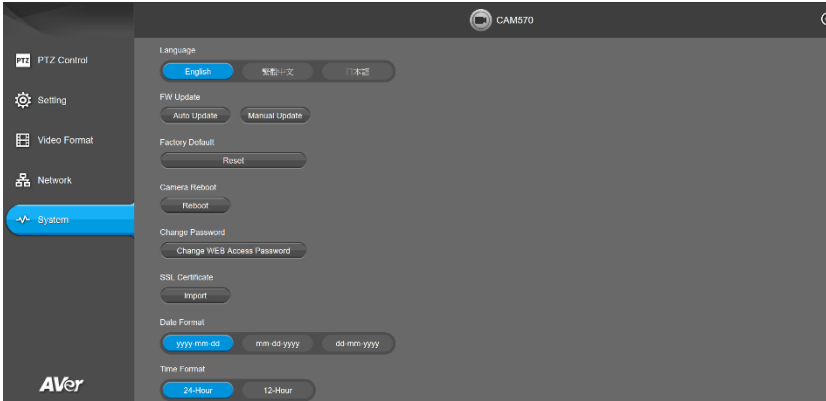

Item	Description
Language	Select a language for the web interface.
Firmware Update	Update your camera's firmware. <ul style="list-style-type: none"> ● Auto Update: Checks and updates online. ● Manual Update: Update the firmware using a file offline. <p>Note: The camera will reboot and the connection will be lost. Please wait a few minutes and keep the power cable connected. Unplugging the cable during this process may damage the device.</p>
Factory Default	Reset your camera to factory default settings. You can choose to keep the IP address by selecting the checkmark. <ul style="list-style-type: none"> ● If you forgot your password, use PTZApp 2 to reset the web interface password to the default aver4321.
Camera Reboot	Reboot the camera.
Change Password	Change the web interface password. <ul style="list-style-type: none"> ● Use 6-10 characters, upper and lowercase letters, numbers and special characters (* ! % + = , - _ ^ / @ . ~). ● If you forgot your password, use PTZApp 2 to reset the web interface password to the default aver4321.
SSL Certificate	Upload an SSL certificate.
Date Format	Select a date format.
Time Format	Select a time format.
Time Correction Mode	Select a time correction mode. <ul style="list-style-type: none"> ● Auto: Enter your Network Time Protocol (NTP) server URL to synchronize the clock. The default NTP server is located in the US. ● Manual: Click the pencil icon to set up the clock.
Allow Providing of Anonymous	Opt-in or opt-out of providing usage data.

Usage Data	
Information	Displays your camera information such as IP address.

PTZApp 2

Install PTZApp 2

1. Download PTZApp 2 to your computer from the official website (<https://communication.aver.com/model/ptzapp2>) or AVer Download Center. (<https://www.aver.com/download-center>).
2. Double-click the downloaded .exe file.
3. Follow the instructions displayed on the setup wizard to install PTZApp 2.
4. You'll be prompted to install plug-ins for additional features.
Besides **Main App**, also select **Install to support IP virtual streaming...** on Windows or authorize with your username and password on Mac.

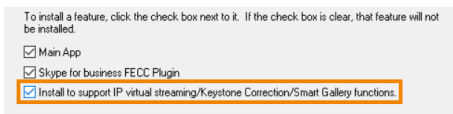

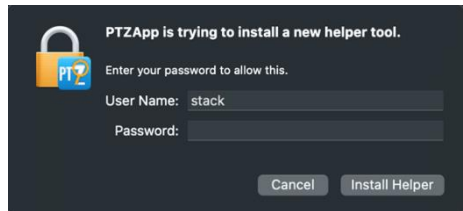

Windows



Mac

Open and Quit PTZApp 2

1. Double-click the PTZApp 2 icon  to open PTZApp 2 in your browser.
2. Connect your AVer camera to your computer with a USB cable. When PTZApp 2 detects a USB-connected camera, a camera card will appear under USB Devices.
3. Click **Setting** on your camera card for pan, tilt and zoom controls, presets, and advanced settings.
4. To quit PTZApp 2, click the **Show Hidden Icons** arrow on the taskbar, right-click the PTZApp 2 icon , and select **Quit**.
5. If you can't open PTZApp 2 after installation, click the **Show Hidden Icons** arrow on the taskbar, right-click the PTZApp 2 icon , and select **Restore**.

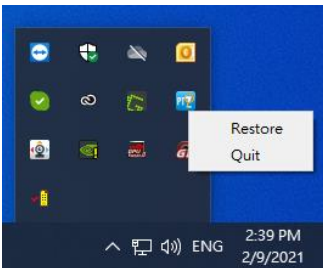

Use PTZApp 2 with USB Devices

1. Run your video application and make a video call.
2. During your video call, you can use the PTZApp 2 to pan, tilt and zoom the camera in/out and enable/disable the WDR, brightness, and sharpness feature.
3. Launch PTZApp 2 () and it will open in Chrome browser automatically.

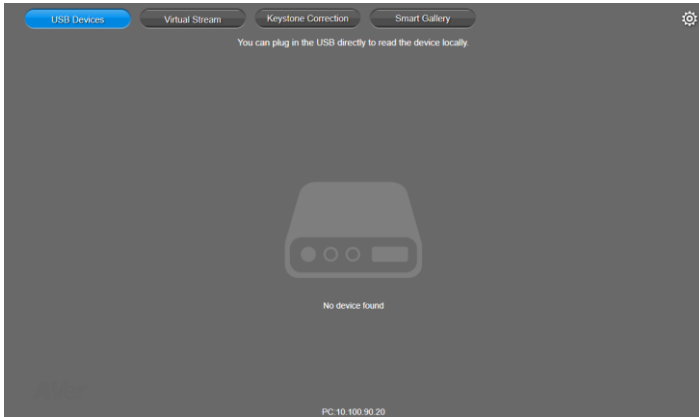

4. Choose “USB device” and connect CAM570 to PC/laptop with USB cable. When the camera is detected, the product card will show up.

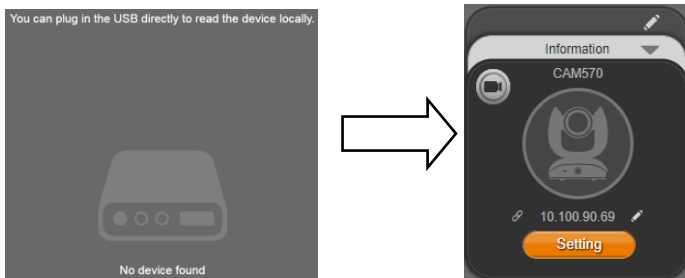

5. Set up IP address. The camera default IP address is **192.168.1.168**. Click pencil icon (✎) to edit IP address.

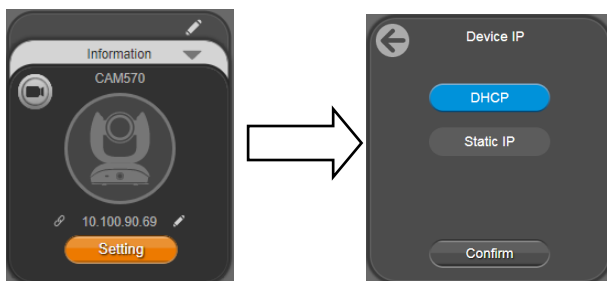

6. Click the setting icon to change Language, Hotkey Control, and PTZApp 2 Version.

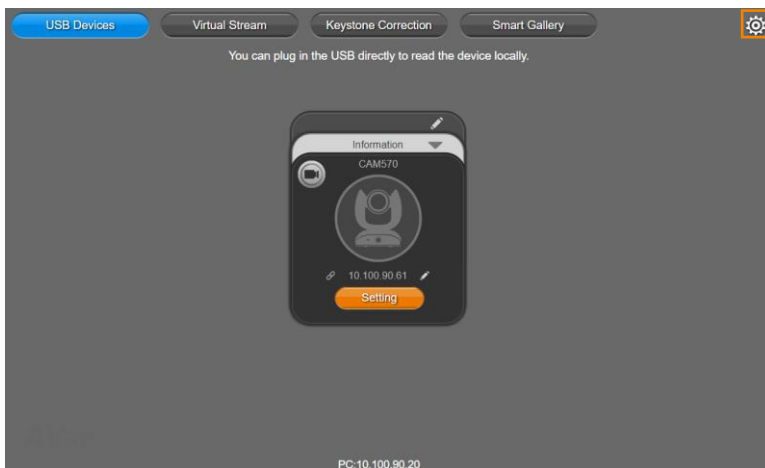

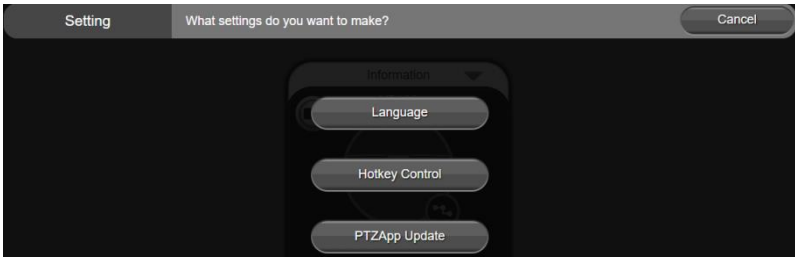

- **Language:** Select desired language and click the check icon to confirm the selection.



- **Hotkey Control:** User can control the camera by using keyboard. This is a general list for all AVer USB Cameras. Backlight control equals to WDR function in CAM570.

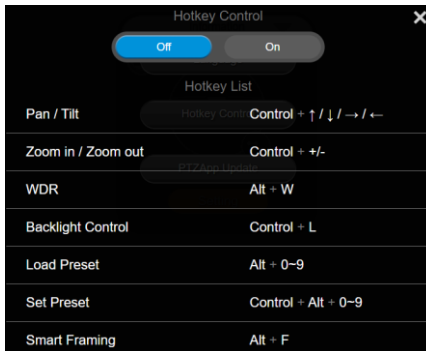

- **PTZApp Update:** Get current PTZApp 2's version number and do auto update here.





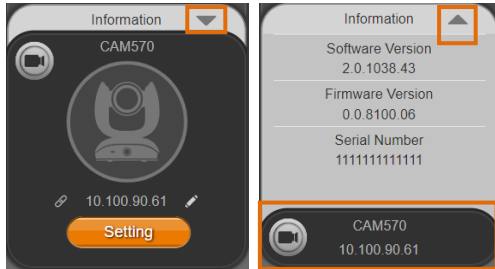

7. **Information:** Click the drop-down triangle icon to review the information of camera. To minimize the information, click the triangle or the bottom area of the information icon.

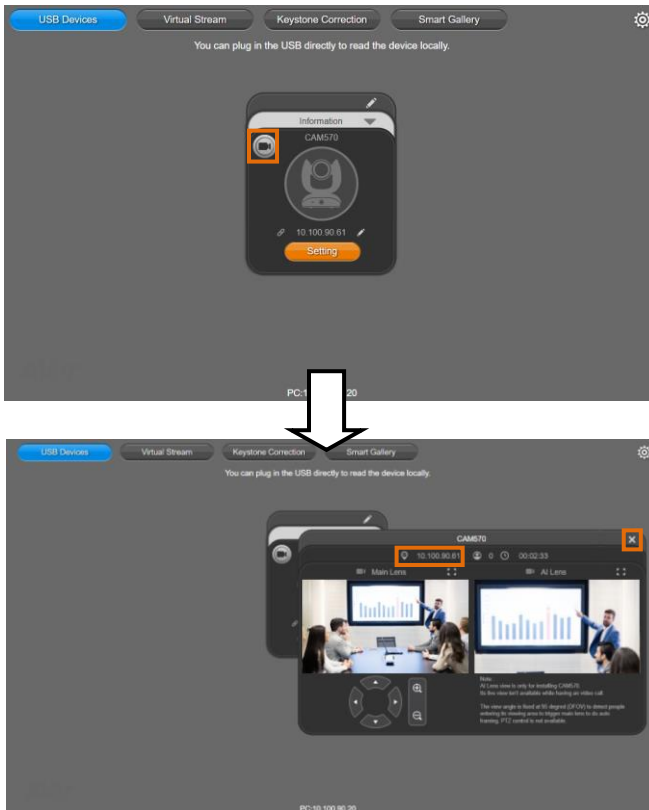



8. **Camera:** Click the camera icon to view the camera live view. IP address is displayed as well. Click the X icon to close the camera live view. If the live video did not appear, please check the camera and the laptop/PC connection to make sure all are correct and well connected.

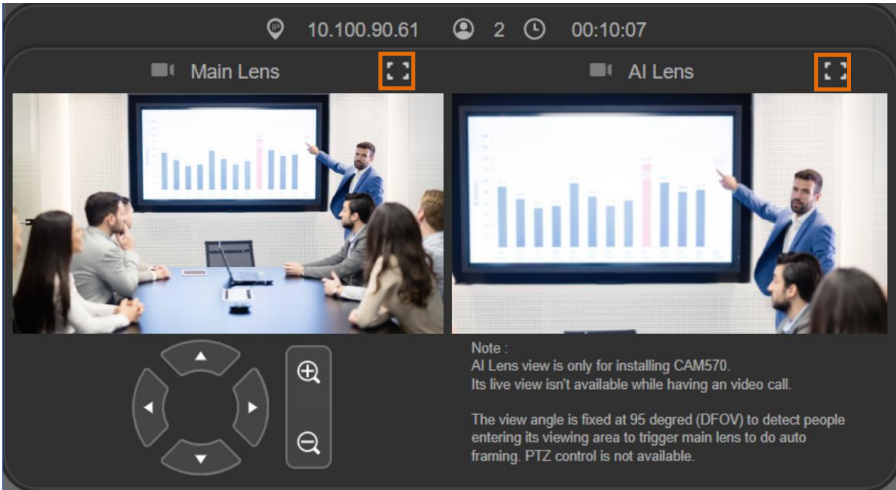

- **Full Screen:** PTZApp 2 can switch to full screen mode. Click   icon and video screen will switch to full screen mode. In full screen mode, user can use direction panel to control camera direction. Click   icon to go back to normal screen view.



- **People Count and Stream Interval:** Click the  icon to show people count number and stream interval. Click the  or  icon to hide the stream interval.

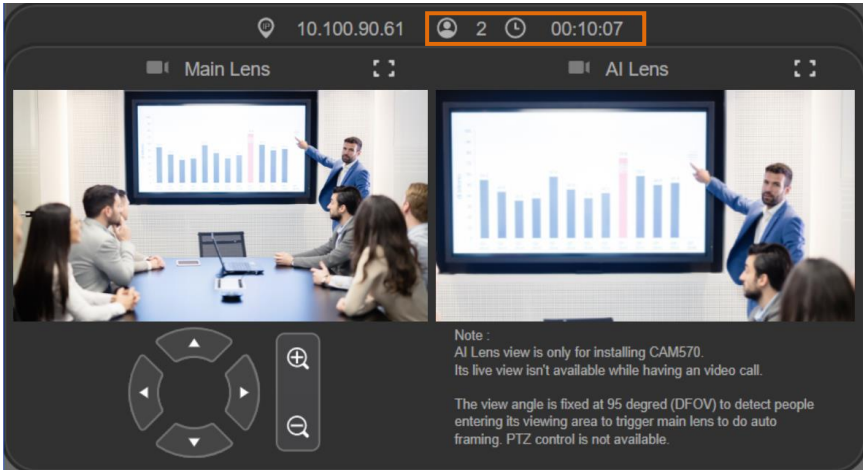

- **Control Panel:** To control the camera direction, zoom in and out during your video call.

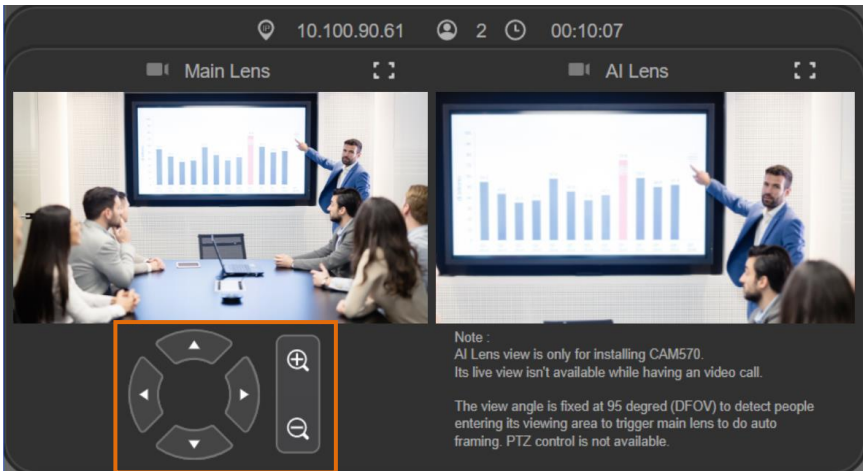

9. **Setting:** Click “**Setting**” button to set up parameters of the camera and speakerphone. Click arrow icon to leave the Setting page.

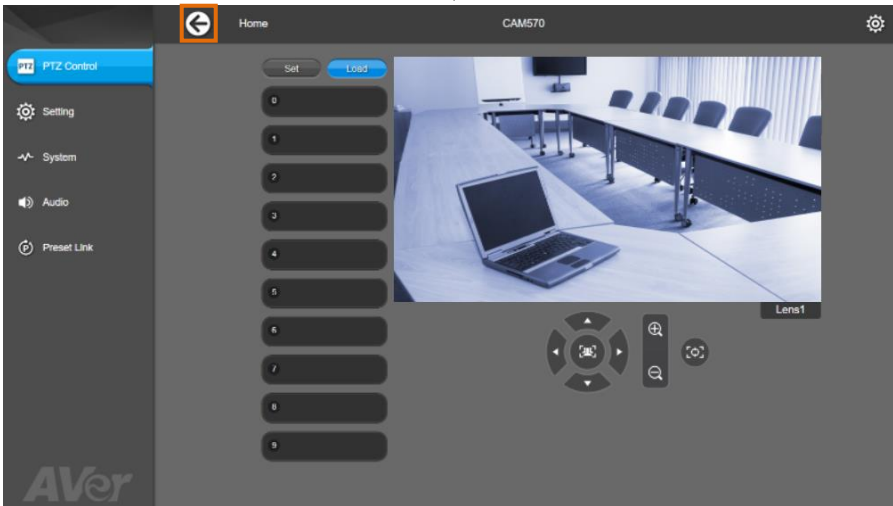
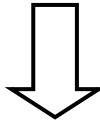
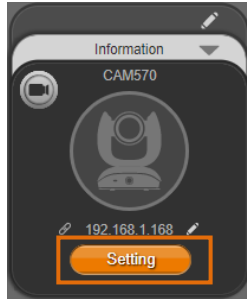

- **PTZ Control:** Use control panel to set up preset positions.
Most settings are the same as those on the web interface. Refer to <[PTZ Control](#)> in the Web Interface chapter for details.
- **Setting:** To set up parameters of the camera.
Most settings are the same as those on the web interface. Refer to <[Setting](#)> in the Web Interface chapter for details.
- **System:** To set up system.
Most settings are the same as those on the web interface. Refer to <[System](#)> in the Web Interface chapter for details.

Virtual Stream

Virtual Stream allows you to send camera video over IP networks to video conferencing software such as Teams, Skype and Zoom.

- Video latency may vary depending on your CPU. We recommend Intel Core i5 or higher.
- Video Stream transmits video only.

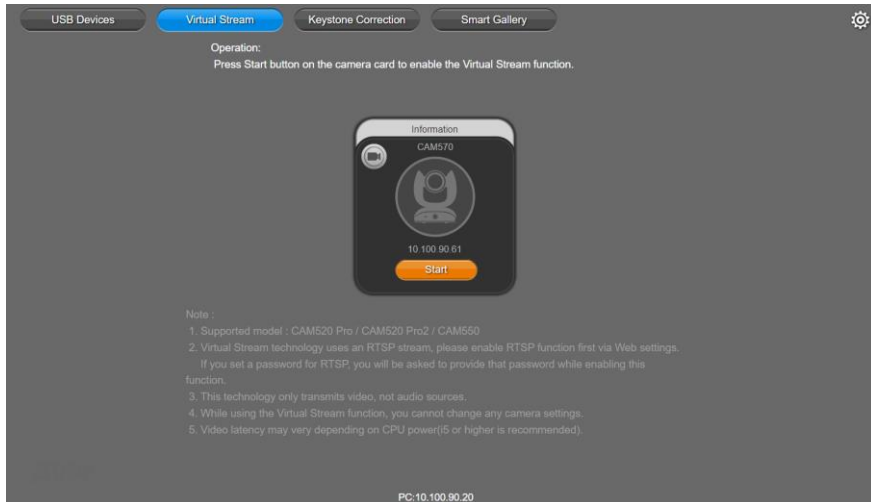

To start a virtual stream:

1. Make sure your camera and computer running the video conferencing software are connected to the same network.
2. Make sure you have enabled your camera's RTSP setting on its web interface.
3. Go to **Virtual Stream** > click **Start** on your camera card.
4. Enter the RTSP password when prompted, if any.
5. Open your video conferencing software. Choose **AVer USB VCam** as the video source, not your camera model name.
6. For pan, tilt and zoom controls, use a remote control or VISCA commands.

To stop a virtual stream:

Click **Stop** on your camera card.

Smart Gallery

Smart Gallery creates a close-up frame for each participants and present them in a single stream composited gallery.

- Smart Gallery supports 10-20 people depending on your AVer camera model.
- To create better close-ups, allow some space between participants.
- To set up your camera, stop Smart Gallery, return to **USB Devices** page, and then click **Setting** on your camera card.

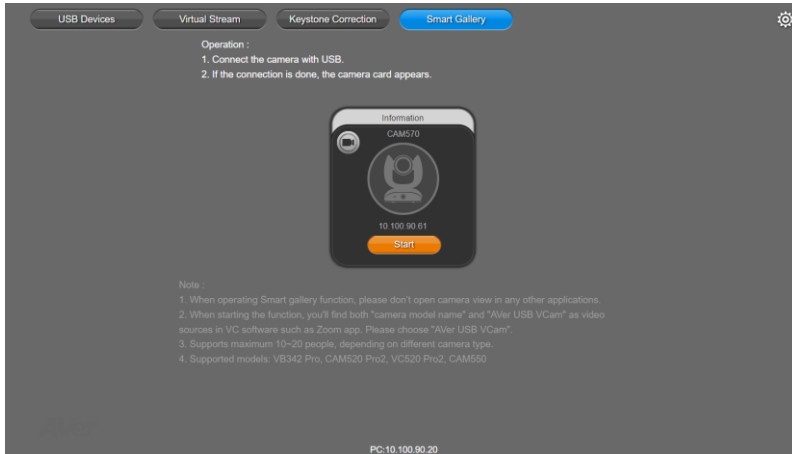

To use Smart Gallery:

1. Connect your camera to the computer with a USB cable.
2. Go to **Smart Gallery** > click **Start** on your camera card.
3. Select a layout.



4. Open your video conferencing software. Choose **AVer USB VCam** as the video source, not your camera model name.

To stop using Smart Gallery:

Click **Stop** on your camera card.

Audio Setting

After enabling the Audio Tracking function, you can further set up the Audio Setting to avoid the camera from tracking to the sound from the audio-output devices rather than the live sound from the presenters or participants. The audio-output device could be a standalone speaker, PC, HDMI devices or speakers used to play the RTSP/RTMP streams.

To enable Audio Tracking function, please refer to **Audio Tracking** in the <[Tracking Mode](#)> chapter. To enter the Audio Setting page, on the Main Page of PTZApp 2, click **Setting > Audio**.

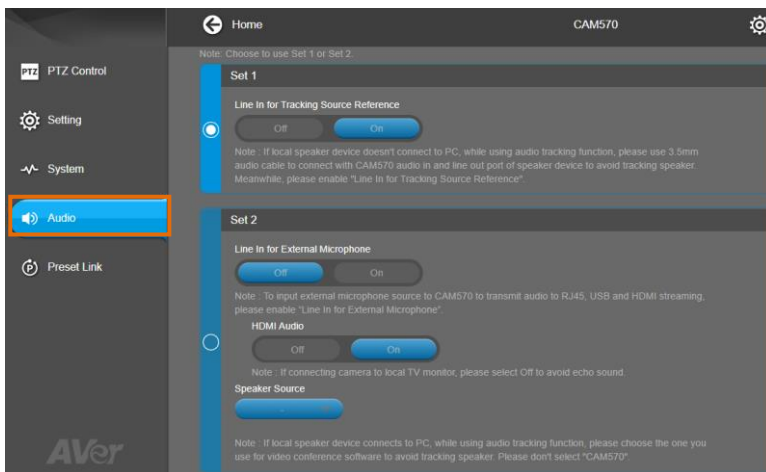
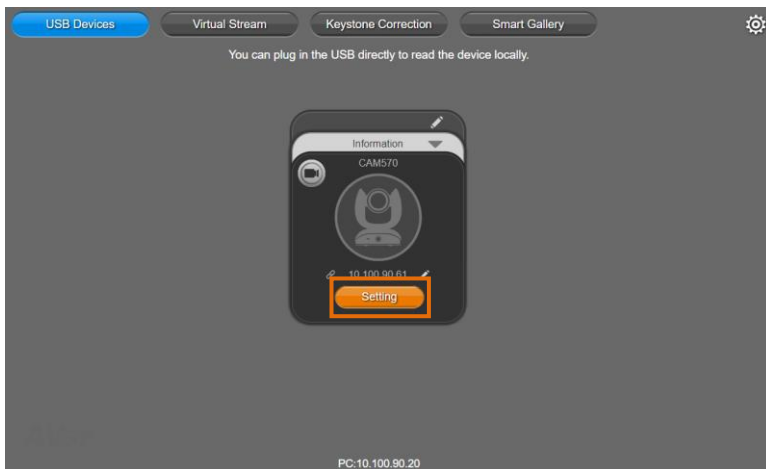

Depends on the audio-output devices, you can use either **Set 1** or **Set 2** to configure the audio setting.

Please refer to the instructions in the below scenarios.

Scenario 1: For the environment with a camera and a standalone speaker on the local side. The speaker is not connected to the computer; and the Audio Input port of the camera is not in use (not connected to an external microphone), please use **Set 1**, which is set as default. This is a scenario for a meeting room with a speaker on the table without connecting to any computers. In order for the camera to track the voices from the participants in the meeting room instead of the sound from the speaker, you will have to define the speaker as an audio reference for the camera. To do so,

1. In **Set 1**, select **On** in the **Line In for Tracking Source Reference** field.

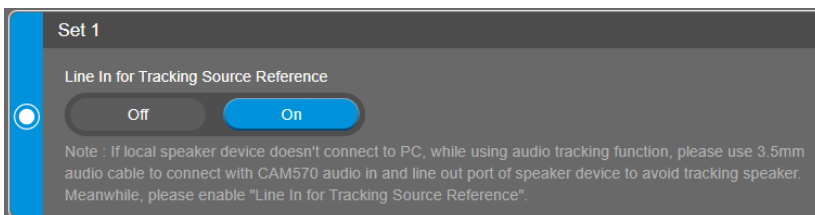

2. Use a 3.5mm audio cable to connect the Line-Out port of the speaker to the Audio-Input port of the camera.

Scenario 2: For the environment with a camera, and a speaker connected to a computer on the local side, while the Audio Input port of the camera is not in use (not connected to an external microphone), please use **Set 2**.

In this scenario, the speaker has been connected to a computer, which may generate the sound of the participants from the remote side. In order for the camera not to track the voices from the speakers, you will have to select the speaker as the **Speaker Source**, so the camera will not track the speaker source. To do so,

1. Turn off **Set 1**.

In **Set 1**, select **Off** in the **Line In for Tracking Source Reference** field.

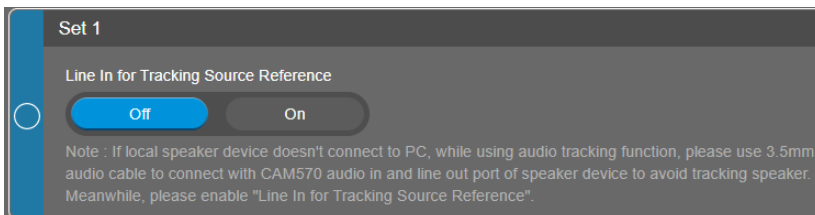

2. In **Set 2** :

- a. Select **Off** in the **Line In for External Microphone** field.
- b. Select the speaker you are using for the conference from the **Speaker Source**.
- c. A dialog will appear “The function needs to restart the system. It will take around 20~60 seconds.”. Click **Confirm**.

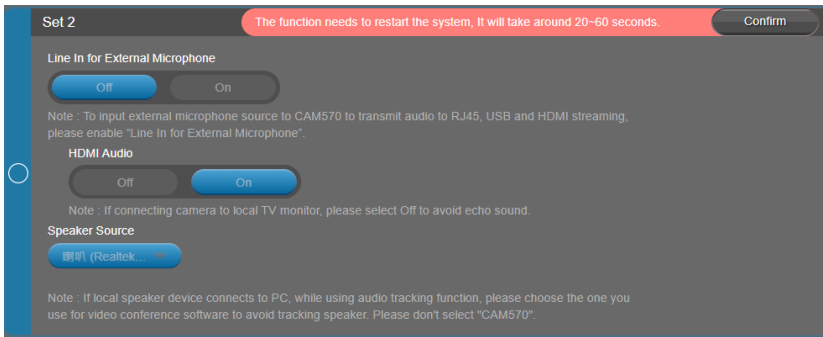

3. The setup is completed.

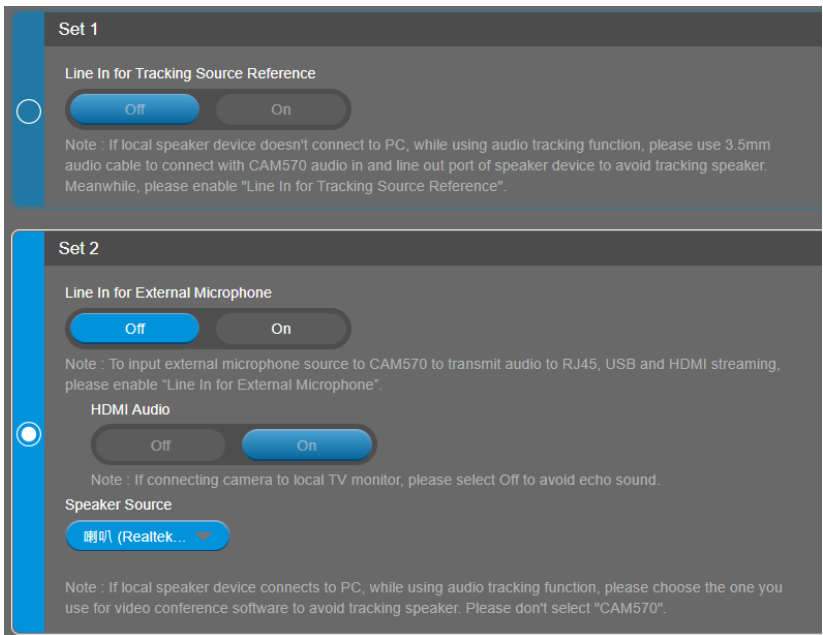

Scenario 3: For the environment with an external microphone connected to the Audio-Input port of the camera, while the camera is also connected to multimedia devices, such as a TV, monitor, computer or the devices used to play the RTSP/RTMP video/audio streams, in this circumstance, please use **Set 2**. Since an external microphone has been connected to the camera, the voices received from the external microphone can be transferred to the multimedia devices connected to the camera, e.g. HDMI monitor. In order for the camera not to track the voices from the multimedia speakers, you will have to enable the **Line In for External Microphone** and select the multimedia speaker as the **Speaker Source**, so the camera will not track the speaker source. To do so,

1. Turn off **Set 1**.

In **Set 1**, select **Off** in the **Line In for Tracking Source Reference** field.

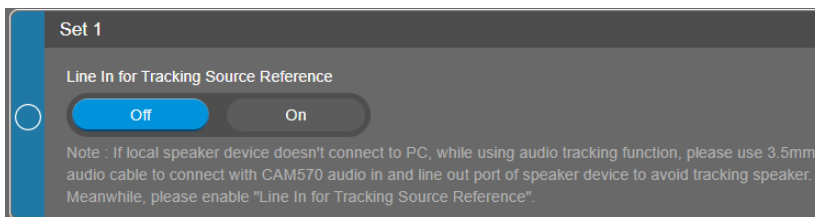

2. In **Set 2**, Select **On** in the **Line In for External Microphone** field. A dialog will appear "The function needs to restart the system. It will take around 20~60 seconds."

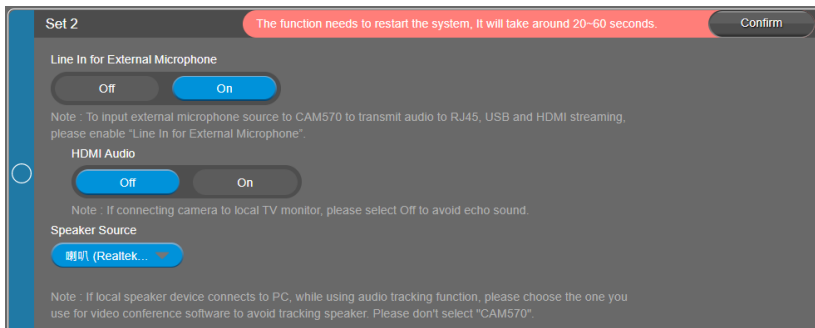

3. Set up the **Speaker Source** based on the multimedia device you use.
 - If the speaker is from an USB device, e.g. a computer: In the **Speaker Source** field, select the speaker of the computer used for the conference.
 - If the speaker is from a multimedia device used to play the RTSP/RTMP video/audio streams: In the **Speaker Source** field, select the speaker used to play the RTSP/RTMP streams.
 - If the speaker is from an HDMI device, e.g. a TV, monitor or a video capture card:
For TV or monitor: In the **HDMI Audio** field, select **Off** to fix voice echoing during the video conference.
For video capture card: In the **HDMI Audio** field, select **On**.

4. Click the **Confirm** button in the above dialog field. The setup is completed.

The image shows a software interface for audio settings, divided into two sections: Set 1 and Set 2. Each section has a title, a sub-title, a toggle switch, and a note.

Set 1

Line In for Tracking Source Reference

Off On

Note : If local speaker device doesn't connect to PC, while using audio tracking function, please use 3.5mm audio cable to connect with CAM570 audio in and line out port of speaker device to avoid tracking speaker. Meanwhile, please enable "Line In for Tracking Source Reference".

Set 2

Line In for External Microphone

Off On

Note : To input external microphone source to CAM570 to transmit audio to RJ45, USB and HDMI streaming, please enable "Line In for External Microphone".

HDMI Audio

Off On

Note : If connecting camera to local TV monitor, please select Off to avoid echo sound.

Speaker Source

喇叭 (Realtek...)

Note : If local speaker device connects to PC, while using audio tracking function, please choose the one you use for video conference software to avoid tracking speaker. Please don't select "CAM570".

EZLive

Please go to <http://www.aver.com/download-center> to download the AVer EZLive software. After downloading, double-click on the file and follow the on-screen instructions to complete the installation.

Use AVer EZLive

During a video call, EZLive can help user to do:

- (1) Camera ePTZ
- (2) Volume control for the speaker connected
- (3) Capture camera's still images
- (4) Record video
- (5) Live stream to Youtube, Livehouse.in, USTREAM...etc.
- (6) Camera Zoom in/out
- (7) Capture PC screen shot
- (8) Record PC screen video
- (9) Set up livestream
- (10) Open file management to retrieve photos and video files
- (11) Livestream setting
- (12) Drawing tool

